

Technical Data Manual

for use by heating contractor

VIESSMANN®



VITOCROSSAL 300



Vitocrossal 300, CT3 boiler
with Vitotronic control

Product may not be exactly as shown

Vitocrossal 300

CT3 Series

High efficiency, gas-fired condensing boiler

for natural gas or liquid propane

with vertical Inox-Crossal heat exchanger surfaces of corrosion-resistant stainless steel.

For operation without low limit on boiler return water temperature.

For closed loop hot water heating systems with
maximum supply water temperatures of 210° F (99° C)

for a maximum operating pressure of 30 psig.

Heating input: 638 to 3361 MBH

187 to 985 kW

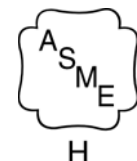

Vitocrossal 300

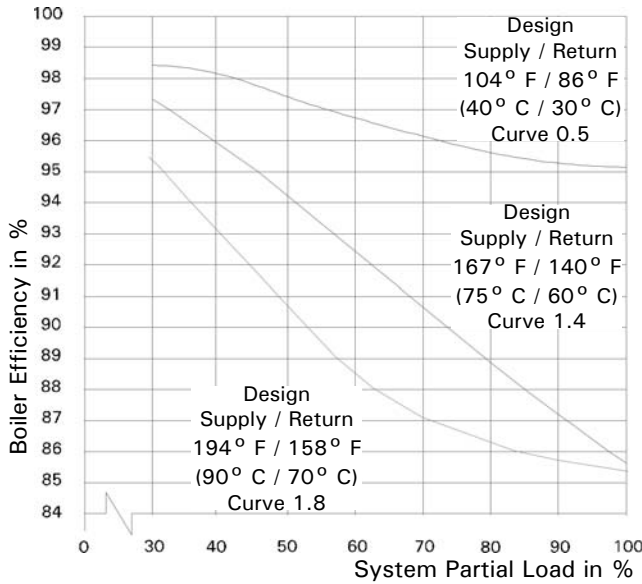

The benefits at a glance:

- Vertical Inox-Crossal heating surfaces for high operational reliability and long service life.
 - Easy dispersal of condensate through vertical gas flues; therefore no concentration of condensate.
 - Increased self-cleaning effect through smooth stainless steel surfaces.
- Highly efficient heat transfer and high condensation rate through
 - heat exchanger surfaces which intensely turbulate the flue gas flow
 - boiler water and hot gases flowing in counterflow.
- Efficiency up to 98.3% through intensive condensation. The flue gas temperature is only approx. 9 - 27° F (5 - 15° C) above boiler return temperature.
- Clean combustion – through perfect match of burner and boiler, low combustion chamber loading and straight-through combustion chamber.

Note: Vitocrossal 300 boiler efficiency dependent on system heating water return temperatures and load conditions

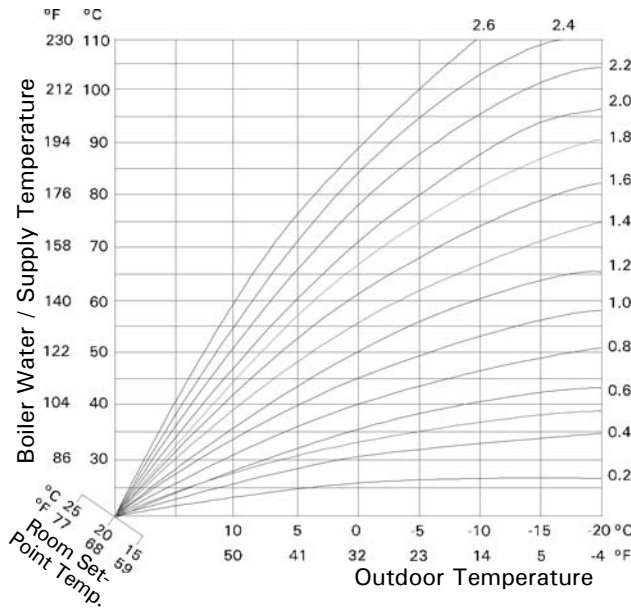

- Two return connections – providing separate connection for heating circuits with lower return temperature. This leads to increased hot gas condensation.
- Easy handling in boiler rooms through particularly low build height and weight; also available in sections.
- Easy installation and elimination of wiring mistakes with Viessmann prewired plug-in system.
- Heating boiler, heating system control, domestic hot water storage tank and all other Viessmann system technology components are coordinated to one another. All components are design-matched for quick installation.
- Economical and safe heating system operation through Vitotronic digital control system with communication capability. Tailored to every need, covering all known control strategies and applications. Standard LON BUS for complete integration into building management systems. Possible integration into the Vitocontrol control panel.

	Page
Product Information	
VITOCROSSAL 300	2
The benefits at a glance:	2
Cut-Away Section	5
Technical Data	6
Boiler Model.....	6
Input (oil).....	6
Output	6
Combustion efficiency	6
Thermal efficiency	6
Boiler output	6
Boiler standby loss at maximum input.....	6
Dimensions - boiler as shipped.....	6
Boiler support frame.....	6
Boiler Model.....	7
Weight	7
Overall weight complete with insul. and control (less burner)	7
Boiler water content.....	7
Heat exchanger surface	7
water-cooled	7
Max. operating temperature	7
Max. operating pressure	7
Flue gas resistance	7
Boiler connections.....	7
Vent pipe.....	7
Flue gas values.....	7
Pressure at boiler flue outlet.....	7
Dimensions	9
Boiler Model CT3	9
Recommended Minimum Service Clearances	10
Mechanical room	10
Minimum clearances to combustibles	10
Pressure drop (primary circuit)	11
Recommended Flow Rates	11

	Page
Standard Equipment	Standard Equipment 12
Boiler Control Alternatives	Boiler Control Alternatives 12
	For single boiler systems:..... 12
	For multi-boiler system (up to 4 boilers): 12
	For single- or multiple-boiler installations:
	Custom control panels..... 12
System Design Considerations	System Design Considerations 13
	Venting 13
	Condensate and its disposal 13
	ProTech Systems Inc..... 13
	Selkirk Canada Corporation 13
	Security Chimneys International Ltd..... 13
	Van-Packer Co. Inc. 13
	Enervex Inc. (formerly Exhausto)..... 13
	Design notes regarding draining condensate 14
	Combustion air supply 14
	Warranty 14
	System layout 14
	Water quality 14
	Oxygen diffusion barrier under floor tubing..... 14
	Boiler/Burner start-up 15
	Sound attenuation 15
	Airborne noise attenuation 15
	Anti-vibration measures 15
	Seismic restrainer 15
	Burner Alternatives 16
	Weishaupt Burners - Linkage-less version 16
	Riello Burners 16

Cut-Away Section

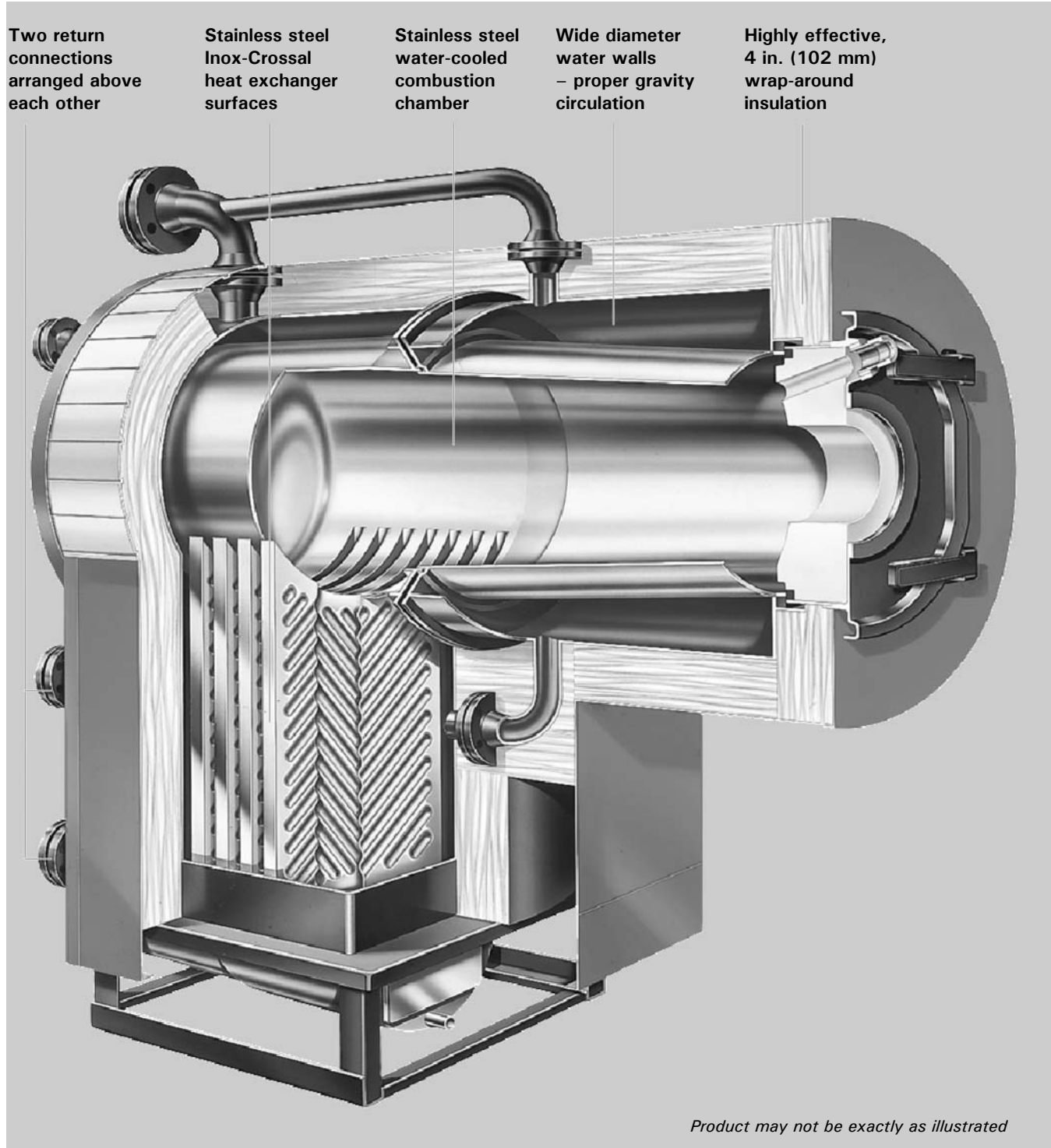

Technical Data

Boiler Model	CT3-	17	22	28	37	46	57	72	89
Input	MBH (kW)	638 (187)	846 (248)	1071 (314)	1389 (407)	1726 (506)	2160 (633)	2702 (792)	3361 (985)
Output*1	MBH (kW)	626 (183)	827 (242)	1044 (306)	1350 (396)	1675 (491)	2094 (614)	2616 (767)	3252 (953)
Combustion efficiency	%	98.3	97.8	97.4	97.2	97.1	96.9	96.8	96.7
Thermal efficiency	%	98.1	97.7	97.4	97.2	97.1	96.9	96.8	96.7
Boiler output at	MBH (kW)	554 (162.3)	734 (215.3)	930 (272.6)	1206 (353.3)	1502 (440.2)	1879 (550.7)	2351 (689.0)	2924 (857.0)
176/140° F (80/60° C)									
158/122° F (70/50° C)	MBH (kW)	576 (168.7)	763 (223.7)	966 (283.2)	1253 (367.1)	1561 (457.4)	1953 (572.2)	2443 (716.0)	3038 (890.4)
104/86° F (40/30° C)	MBH (kW)	607 (177.8)	805 (235.8)	1019 (298.6)	1321 (387.1)	1645 (482.2)	2059 (603.2)	2575 (754.8)	3203 (938.7)
Boiler standby loss	Btu/h	2566	2818	3064	3583	4299	5240	5753	6633
at maximum input	W	752	826	898	1050	1260	1536	1686	1944
176/140° F (80/60° C)	%	0.40	0.33	0.29	0.26	0.25	0.24	0.21	0.20
158/122° F (70/50° C)	Btu/h	2139	2347	2552	3047	3583	4367	4794	5753
	W	627	688	748	893	1050	1280	1405	1686
	%	0.34	0.28	0.24	0.22	0.21	0.20	0.18	0.17
104/86° F (40/30° C)	Btu/h	856	938	1020	1143	1433	1747	1918	2211
	W	251	275	299	335	420	512	562	648
	%	0.13	0.11	0.10	0.08	0.08	0.08	0.07	0.07
Dimensions - boiler as shipped	in. (mm)	59¾ (1516)	62¾ (1594)	66 (1675)	69 (1751)	72¼ (1829)	78¼ (1985)	82¼ (2095)	90 (2289)
(p) Length (door removed)									
(q) Width 1 (max. shell width)	in. (mm)	27 (684)	27 (684)	27 (684)	31½ (800)	31½ (800)	31¼ (800)	37½ (951)	37½ (951)
(r) Height*2 (max.)	in. (mm)	697/8 (1773)	71⅞ (1808)	71¼ (1811)	79⅝ (2023)	79⅝ (2023)	79⅝ (2023)	88 (2235)	88 (2235)
Overall dimensions	in. (mm)	64¼ (1636)	67½ (1714)	70½ (1795)	73½ (1871)	76¾ (1949)	83 (2105)	85½ (2172)	93¼ (2366)
(s) Overall length									
(t) Overall width (incl. insulation and control)	in. (mm)	40 (1016)	40 (1016)	40 (1016)	44½ (1132)	44½ (1132)	44½ (1132)	49 (1249)	49 (1249)
(u) Overall height (to top of installed header)	in. (mm)	797/8 (2027)	81⅞ (2062)	81¼ (2065)	93 ⁵ / ₁₆ (2370)	93 ⁵ / ₁₆ (2370)	93 ⁵ / ₁₆ (2370)	101¾ (2585)	101¾ (2585)
(v) Width (upper with jacketing)	in. (mm)	34½ (874)	34½ (874)	34½ (874)	39 (990)	39 (990)	39 (990)	45⅞ (1147)	45⅞ (1147)
(w) Width (lower with jacketing)	in. (mm)	31½ (798)	31½ (798)	31½ (798)	36 (914)	36 (914)	36 (914)	39 (990)	39 (990)
Boiler support frame	in. (mm)	35¼ (895)	38⅝ (975)	41½ (1055)	47¼ (1200)	50 (1270)	56¼ (1430)	56¼ (1430)	64⅞ (1630)
(x) Length									
(y) Width	in. (mm)	27¼ (690)	27¼ (690)	27¼ (690)	32½ (800)	32½ (800)	32½ (800)	35½ (900)	35½ (900)
(z) Height	in. (mm)	2¾ (70)	2¾ (70)	2¾ (70)	2¾ (70)	2¾ (70)	2¾ (70)	2¾ (70)	2¾ (70)

*1 Tested to AHRI BTS-2000 "method to determine efficiency of commercial space heating boilers".

*2 Boilers CT3-17, 22, 28 are shipped with header attached (u) - see overall height dimensions and add 4 in. (100 mm) for the wood blocks as per transportation height.

Technical Data *(continued)*

Boiler Model	CT3-	17	22	28	37	46	57	72	89
Weight	lbs	1012	1114	1202	1671	1759	1995	2706	3014
boiler shell	(kg)	(459)	(505)	(545)	(758)	(798)	(905)	(1230)	(1370)
front cone (includes combustion chamber door)	lbs	413	413	413	490	490	490	600	600
	(kg)	(187)	(187)	(187)	(222)	(222)	(222)	(273)	(273)
Overall weight complete with insul. and control (less burner)	lbs	1228	1352	1455	1962	2064	2322	3014	3344
	(kg)	(557)	(613)	(660)	(890)	(936)	(1053)	(1370)	(1520)
Boiler water content	USG	71.3	78.2	87.2	129.5	140.8	150.6	199.2	221.9
	(L)	(270)	(296)	(330)	(490)	(533)	(570)	(754)	(840)
Heat exchanger surface	ft. ²	85.0	107.6	123.8	176.5	200.2	245.4	316.5	383.2
water-cooled	(m ²)	(7.9)	(10.0)	(11.5)	(16.4)	(18.6)	(22.8)	(29.4)	(35.6)
Max. operating temperature	°F	210							
	(°C)	(99)							
Max. operating pressure	psig	30							
	kpa	(207)							
Flue gas resistance	"w.c.	0.40	0.56	0.64	0.80	0.88	1.08	1.20	1.32
	Pa	(100)	(140)	(160)	(200)	(220)	(270)	(300)	(330)
Boiler connections	in.	2½	2½	3	4	4	4	5	5
boiler supply (BS) & return (BR1)	(mm)	(65)	(65)	(80)	(100)	(100)	(100)	(125)	(125)
Boiler return (BR2) ^{*3}	in.	2	2	2	3	3	3	4	4
	(mm)	(50)	(50)	(50)	(75)	(75)	(75)	(100)	(100)
Safety supply	in.	1¼	1¼	2	2	2	2	2½	2½
	(mm)	(32)	(32)	(51)	(50)	(50)	(50)	(65)	(65)
Boiler drain	in.	1	1	1	1	1	1	1	1
Condensate drain	in.	½	½	½	½	½	½	½	½
Vent pipe	in.	8	8	8	10	10	10	12	12
internal Ø	(mm)	(201)	(201)	(201)	(251)	(251)	(251)	(301)	(301)
Flue gas values^{*4}	°F	113	113	113	113	113	113	113	113
Temperature (at a return temperature of 86° F (30° C) - at rated input	(°C)	(45)	(45)	(45)	(45)	(45)	(45)	(45)	(45)
- at partial load	°F	104	104	104	104	104	104	104	104
	(°C)	(40)	(40)	(40)	(40)	(40)	(40)	(40)	(40)
Temperature (at a return temperature of 140° F (60° C)	°F	167	167	167	167	167	167	167	167
	(°C)	(75)	(75)	(75)	(75)	(75)	(75)	(75)	(75)
Mass flow rate (of flue gas)	lbs/h	704	928	1179	1531	1903	2380	2979	3705
	(kg/h)	(320)	(422)	(536)	(696)	(865)	(1082)	(1354)	(1684)
Gas volume of combustion chamber and heat exchanger	ft. ³	8.83	9.92	12.00	15.90	18.40	21.54	40.61	42.73
	(m ³)	(0.250)	(0.281)	(0.340)	(0.450)	(0.521)	(0.610)	(1.150)	(1.210)
Pressure at boiler flue outlet	Pa	±0	-3	±0	-5	±0	±0	±0	±0
- at partial input									
- at maximum input	Pa	-3	-4	-2	±0	±0	±0	±0	±0

^{*3} Boiler has two return connections - the heating return with the lower temperature should be connected to the boiler return BR1.

^{*4} Values for calculating the size of the flue system based on 10% CO₂ for natural gas. Flue gas temperatures measured as gross values at 68° F (20° C) combustion air temperature. The details for partial load refer to an output of 30% of rated input. Calculate the flue gas mass flow rate accordingly when the partial load differs from that stated above (subject to the burner mode).

► For information regarding other Viessmann System Technology componentry, please reference documentation of respective product.

Technical Data *(continued)*

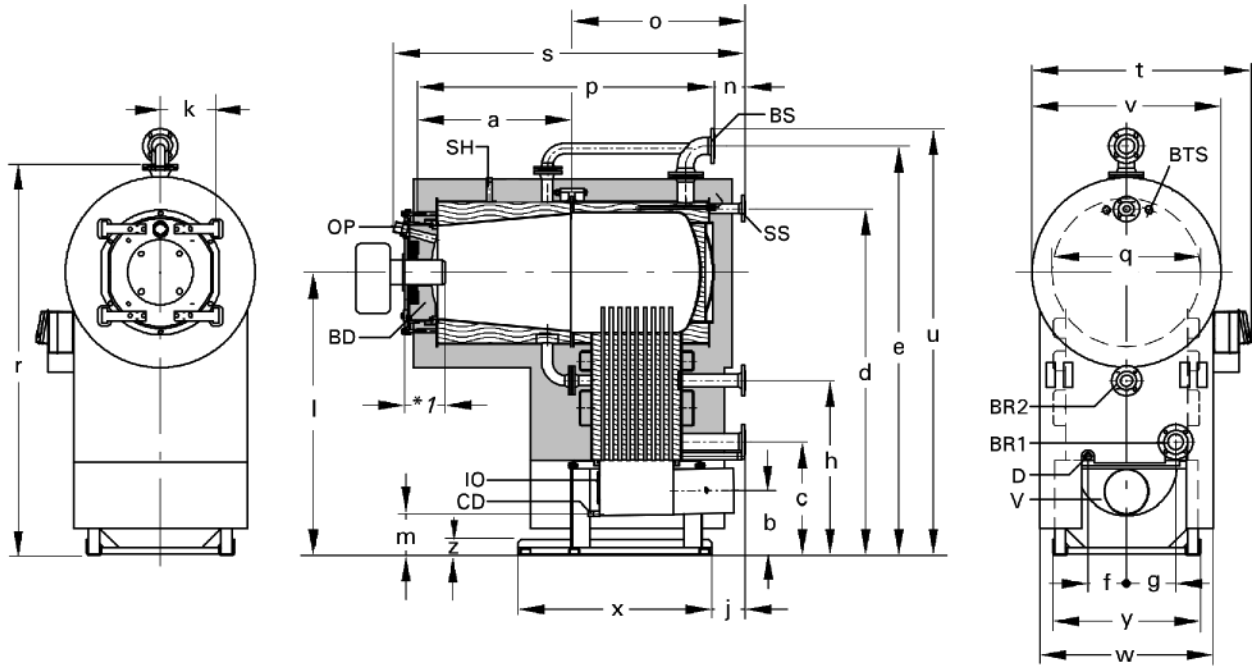

Legend

- V Vent pipe connection
- SH Female connection R ½ in. for air vent and pressure gage
- D Drain
- CD Condensate drain
- BR 1 Boiler return 1
- BR 2 Boiler return 2
- BTS Boiler temperature sensor
- BD Boiler door with burner connecting flange
- BS Boiler supply
- IO Inspection opening
- SS Safety supply for pressure relief valve
- OP Observation port (boiler from CT3-17 - 28: offset by 90°)

- Note:** - Dimensions p through z shown above are listed on page 6.
 - Minimum shipping dimensions: use "o" in the table below, and height, width q or y (which ever is larger) in the diagram above.

*1 The minimum combustion head length of 5 ½ in. (140 mm) must be maintained. When a burner with a shorter combustion head is used, all functions including combustion results must be verified. The maximum combustion head length must also be observed so that the burner on the hinged combustion chamber door can swing into service position. Radius of door hinge to outside combustion head: 18 ¾ in. (476 mm).

Technical Data *(continued)*

Dimensions									
Boiler Model	CT3-	17	22	28	37	46	57	72	89
a	in. (mm)	28 ¹ / ₈ (715)	28 ¹ / ₈ (715)	28 ¹ / ₈ (715)	29 ⁵ / ₈ (751)	29 ⁵ / ₈ (751)	29 ⁵ / ₈ (751)	29 ³ / ₄ (755)	29 ³ / ₄ (755)
b	in. (mm)	11 ³ / ₄ (298)	11 ³ / ₄ (298)	11 ³ / ₄ (298)	12 ³ / ₄ (325)	12 ³ / ₄ (325)	12 ³ / ₄ (325)	14 ¹ / ₄ (363)	14 ¹ / ₄ (363)
c	in. (mm)	20 ¹ / ₂ (518)	20 ¹ / ₂ (518)	20 ¹ / ₂ (518)	22 ³ / ₄ (577)	22 ³ / ₄ (577)	22 ³ / ₄ (577)	25 ¹ / ₄ (644)	25 ¹ / ₄ (644)
d	in. (mm)	62 ³ / ₄ (1594)	64 ¹ / ₄ (1631)	64 ³ / ₄ (1644)	73 (1854)	73 (1854)	73 (1854)	80 ¹ / ₂ (2043)	80 ¹ / ₂ (2043)
e	in. (mm)	76 ³ / ₈ (1940)	78 (1980)	78 ⁵ / ₈ (1996)	88 ³ / ₄ (2254)	88 ³ / ₄ (2254)	88 ³ / ₄ (2254)	97 (2463)	97 (2463)
f	in. (mm)	7 (177)	7 (177)	7 (177)	8 (200)	8 (200)	8 (200)	10 (250)	10 (250)
g	in. (mm)	9 (227)	9 (227)	9 (221)	9 ¹ / ₂ (241)	9 ¹ / ₂ (241)	9 ¹ / ₂ (241)	11 (280)	11 (280)
h	in. (mm)	31 ¹ / ₂ (802)	33 ¹ / ₂ (852)	33 ¹ / ₂ (852)	36 ¹ / ₄ (921)	36 ¹ / ₄ (921)	36 ¹ / ₄ (921)	38 (965)	38 (965)
j	in. (mm)	7 (180)	7 (180)	7 (180)	7 ¹ / ₈ (182)	7 ¹ / ₈ (182)	7 ¹ / ₈ (182)	8 ⁷ / ₈ (225)	8 ⁷ / ₈ (225)
k	in. (mm)	10 (257)	10 (257)	10 (257)	11 ¹ / ₄ (284)	11 ¹ / ₄ (284)	11 ¹ / ₄ (284)	14 (360)	14 (360)
l	in. (mm)	51 ¹ / ₄ (1299)	53 (1349)	53 (1349)	59 (1500)	59 (1500)	59 (1500)	63 ³ / ₄ (1621)	63 ³ / ₄ (1621)
m	in. (mm)	7 ¹ / ₂ (194)	7 ¹ / ₂ (194)	7 ¹ / ₂ (194)	7 ¹ / ₂ (190)	7 ¹ / ₂ (190)	7 ¹ / ₂ (190)	7 ³ / ₄ (197)	7 ³ / ₄ (197)
n	in. (mm)	5 ¹ / ₂ (141)	5 ¹ / ₂ (141)	4 ³ / ₄ (121)	3 (79)	3 (79)	3 (79)	2 ¹ / ₂ (65)	2 ¹ / ₂ (65)
o (split boiler shipping length) Recommended Boiler pad	in. (mm)	37 (942)	40 (1020)	42 ¹ / ₂ (1081)	42 ¹ / ₂ (1079)	45 ¹ / ₂ (1157)	51 ¹ / ₂ (1313)	55 ¹ / ₄ (1405)	63 (1599)
	in. (L) (mm)	47 (1200)	50 (1270)	53 (1346)	59 (1500)	62 (1573)	68 (1727)	76 (1930)	76 (1930)
	in. (W) (mm)	35 (889)	35 (889)	35 (889)	39 (990)	39 (990)	39 (990)	43 (1092)	43 (1092)
	in. (H) (mm)	4 (100)	4 (100)	4 (100)	4 (100)	4 (100)	4 (100)	4 (100)	4 (100)

Recommended Minimum Service Clearances

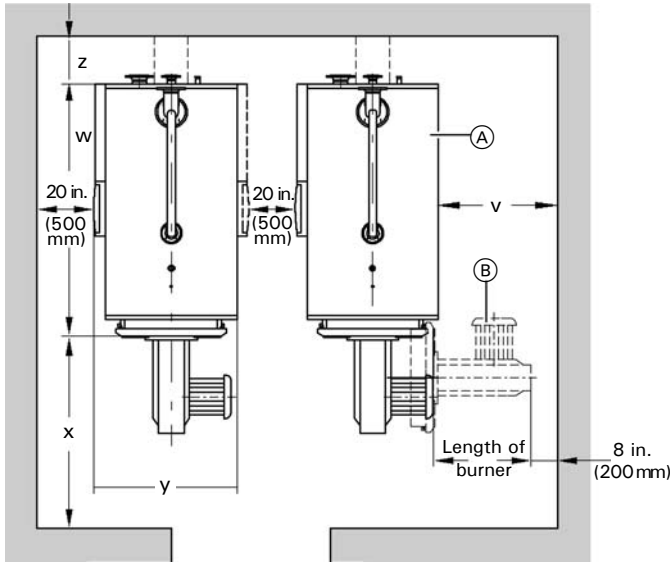

To enable convenient installation and maintenance, observe the stated clearance dimensions. Maintain the minimum clearances where space is tight. In the factory set condition, the boiler door opens to the right. You can relocate the hinge bolts so that the door can open to the left.

Mechanical room

- Do not operate when air is polluted with halogenated hydrocarbons (e.g. as in aerosols, paints, solvents and cleaning agents)
- Prevent very dusty conditions
- Prevent high levels of humidity
- Prevent freezing and ensure good ventilation

Legend

- Ⓐ Boiler
- Ⓑ Burner

Boiler model CT3-		17	22	28	37	46	57	72	89
V	in. (mm)	28 (711)	28 (711)	28 (711)	35 (889)	35 (889)	39 (991)	45 (1143)	45 (1143)
W	in. (mm)	62½ (1593)	65¾ (1671)	69 (1752)	72 (1828)	75 (1906)	81¼ (2062)	85¼ (2172)	93¼ (2366)
X	in. (mm)	36½ (930)	39¼ (1000)	43¼ (1100)	59 (1500)	59 (1500)	59 (1500)	59 (1500)	59 (1500)
Y	in. (mm)	40 (1012)	40 (1012)	40 (1012)	44½ (1128)	44½ (1128)	44½ (1128)	49 (1243)	49 (1243)
Z	in. (mm)	41¼ (1048)	41¼ (1048)	41¼ (1048)	45¼ (1149)	45¼ (1149)	45¼ (1149)	48 (1219)	48 (1219)

Minimum clearances to combustibles

Boiler model CT3-	17	22	28	37	46	57	72	89
Top	6 in. (150 mm)							
Sides	6 in. (150 mm)							
Flue	As per vent manufacturer's specifications							
Front	6 in. (150 mm)							
Floor	combustible							

Pressure drop (primary circuit)

The Vitocrossal 300 boiler is only suitable for heating systems with pumped heating water.

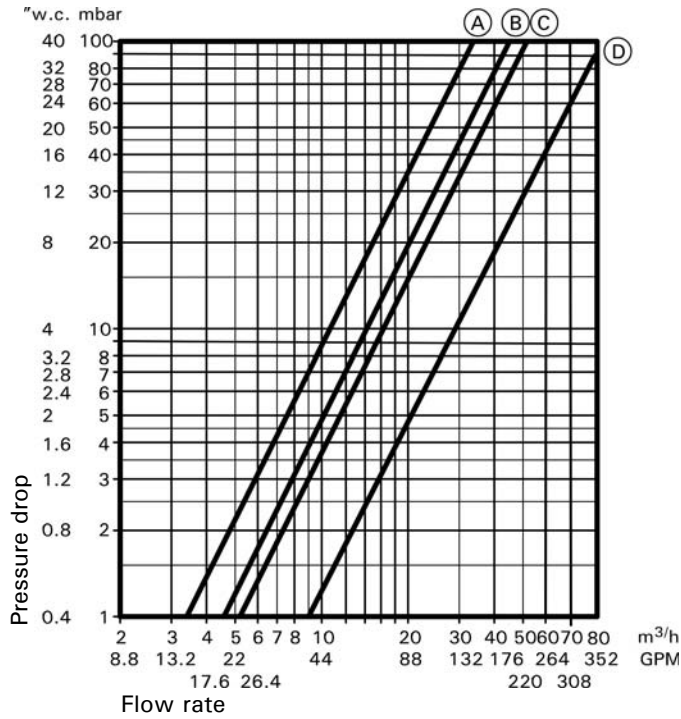

Legend

- (A) CT3-17 to -22
- (B) CT3-28
- (C) CT3-37 to -57
- (D) CT3-72 to -89

Recommended Flow Rates

Boiler model CT3-		17	22	28	37	46	57	72	89
20° F Δt	GPM	61	81	103	134	166	208	260	323
40° F Δt	GPM	31	41	52	67	83	104	130	162
11° C Δt	L/s	3.9	5.1	6.5	8.5	10.5	13.2	16.5	20.4
22° C Δt	L/s	2.0	2.6	3.3	4.2	5.3	6.6	8.2	10.3

Note: Δt = temperature difference
This boiler does not require a flow switch.

Standard Equipment

Note: Boiler controls and burners are purchased separately. Please see Price List for details.

Boiler body and fitted boiler door with burner plate, fitted clean-out cover and fitted mating flanges incl. gaskets on all connectors, with flue gas collector.

For tight spaces, Vitocrossal 300 can also be delivered in sections. The front of the combustion chamber can be removed on site, be brought into the boiler room and refitted there.

- 2 cartons with insulation
- 1 carton containing boiler control unit
- 1 water connection pipe fitted to the boiler skid (from CT3-37)
- 1 burner plate pack
- 1 carton of installation fitting

Standard equipment of installation fittings includes:

- low water cut-off
- safety header (c/w 30 psig pressure relief valve, air vent and pressure gage)
- drain valve
- product documentation

IMPORTANT

Ensure specific regional, provincial, or state requirements, such as fuel train and additional safety control requirements etc., are known before the product order is placed, to determine proper burner selection and pricing.

Boiler Control Alternatives

For single boiler systems:

- without Vitocontrol control panel
 - Vitotronic 100 (type GC1/GC1B) for constant boiler water temperature or outdoor reset mode in conjunction with an external control unit (BMS).
 - Vitotronic 300 (type GW2/GW2B) for modulating boiler water temperature with mixing valve control for a maximum of two heating circuits with mixing valve.
- with Vitocontrol control panel
 - Vitotronic 100 (type GC1/GC1B) and Vitocontrol-S MW1/Vitotronic 300-K MW1B, control panel with outdoor reset mode and mixing valve control for a maximum of 2 heating circuits with mixing valve and additional Vitotronic 200-H, type HK1M/HK1B for additional heating circuits with mixing valve.

For multi-boiler system (up to 4 boilers):

- without Vitocontrol control panel
 - Vitotronic 100 (type GC1/GC1B) and LON module for modulating boiler water temperature in conjunction with an external control unit (BMS).
- with Vitocontrol control panel
 - Vitotronic 100 (type GC1/GC1B) and LON module for modulating boiler water temperature for each boiler of the multi-boiler system and Vitocontrol-S MW1/Vitotronic 300-K MW1B for multi-boiler system, outdoor reset mode and mixing valve control for a maximum of 2 heating circuits with mixing valve and additional Vitotronic 200-H, type HK1M/HK1B for additional heating circuits with mixing valve.

For single-boiler or multiple-boiler installations:

Custom control panels

Custom control panels for residential or commercial applications are designed and manufactured by Viessmann to suit any customer's specific requirements. Custom control panels can have features such as pool heating, hot tub heating, snow melting, telephone tie-in, integration with Building Management Systems, as well as several other functions. Please inquire.

System Design Considerations

Venting

The Vitocrossal 300 boiler is a category IV positive pressure condensing boiler. Each boiler must be vented individually.

Depending on the boiler return water temperature, the flue gases in the boiler are cooled down into the condensation or dew point area of the flue gases. Where they exit the boiler, they reach a relative moisture of 100%. The flue gas temperature is between 9° F / 27° F (5° C / 15° C) higher than the boiler return water temperature.

Therefore, depending on the connected heating system, the flue gas temperature can be between 77° F / 200° F (25° C / 93° C). Due to the low flue gas temperature and the resulting minute updraft conditions, as well as the additional condensation of the flue gases in the venting system, the vent system must be properly designed and suitable materials must be selected. The chimney must be gas and water tight.

Use an AL29-4C® special stainless steel venting system (UL/ULC/CSA listed for category IV) for vertical venting of the Vitocrossal 300 boiler.

	<h3>CAUTION</h3>
<p>Do not use PVC or CPVC material for venting the Vitocrossal 300 boiler.</p>	

Condensate and its disposal

During the operation of the boiler, the amount of condensate to be expected can be read from the diagram below.

The values given are approximate amounts occurring under practical conditions. Not included in the diagram is the amount of condensate occurring in the vent pipe and chimney system. The condensate from the chimney system can be collected together with the condensate from the heating boiler and be disposed of into a floor drain. The condensate will be between 3 and 4 on the pH scale. If local building requirements demand neutralizing the condensate before disposal, contact Viessmann Manufacturing Company Inc. for a correctly sized neutralization tank. The treated condensate will show pH values of between 6.5 and 9 and can then be disposed of into the waste water system.

Note: The “amount of condensate” and the “flue gas temperature gross” graphs are independent of each other.

The following manufacturers may be contacted for suitable stainless steel chimneys:

<p>PolyFlue - Selkirk 5030 Corporate Exchange Blvd. SE Grand Rapids, MI 49512 Canada Contacts Tel. 888-735-5475 Fax. 886-835-9624 USA Contacts Tel. 800-992-8368 Fax. 887-393-4145</p>	<p>ICC - Industrial Chimney Co. 400 J-F Kennedy, St-Jerome, Quebec Canada, J7Y 4B7 Tel. 514-565-6336 Fax: 514-565-6519 Email: sales@ICC-RSF.com</p>
<p>ProTech Systems, Inc. 400 South Pearl Street Albany, NY 12202 Tel. (800) 766-3473</p>	<p>Novaflex 1-20 East Pearce St., Richmond Hill, Ontario, Canada, L4B 1B7 Tel. 905-731-9411 Email: sales@flexmaster.com</p>
<p>Security Chimneys International Ltd. 2125 Rue Monterey, Laval, Quebec H7L 3T6 Tel. 450-973-9999 (US) 1-800-361-4909 (Canada) 1-800-667-3387 Fax: 450-973-2222 Email: infoeng@securitychimneys.com Web: www.securitychimneys.com</p>	

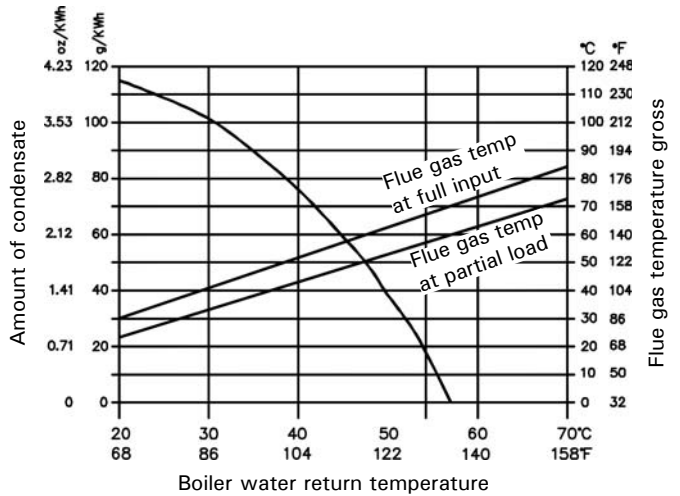

System Design Considerations *(continued)*

Design notes regarding draining condensate

The condensate drain to the sewer connection must be able to be inspected.

Route it with a gradient and equip the pipe with a P-trap; also provide suitable facilities for taking samples.

The bottom drain should be located below the anti-flooding level of the flue gas collector box.

Condensate drains must only be made from corrosion resistant materials (e.g. fibre reinforced hoses). Never use any galvanized materials or those containing copper or black iron for pipes, connectors, etc. Install a P-trap in the condensate drain to prevent flue gases from escaping.

Ensure that the domestic drainage systems are made from materials which are resistant to acidic condensate such as:

- Stoneware pipes
- Hard PVC pipes
- PVC pipes
- PE-HD pipes
- PP pipes
- ABS/ASA pipes
- Stainless steel pipes
- Borosilicate pipes

Combustion air supply

The boiler must not be located in areas or rooms where chemicals containing chlorine, bromine, fluorine, or other corrosive chemicals are stored. Examples include refrigerants, bleach, paint, paint thinner, hair spray, cleaning solvents, water softener salt, etc.

The combustion air must not be contaminated with any amount of the above mentioned chemicals.

Boiler should never be installed in areas where excessive dust, high humidity, or risk of frost exist. Ensure adequate ventilation and supply of fresh combustion air.

Consult your local Viessmann sales representative with uncertainties in regard to a suitable boiler installation location.

This boiler/burner unit needs clean fresh air for safe operation. Provisions for combustion and ventilation air must be made at time of installation. For gas or propane installations, use the "Natural Gas Installation Code CAN/CSA-B149.1 or B149.2" (Canada), or "National Fuel Gas Code ANSI Z223.1" (USA), and/or provisions of local codes.

The sizing methods outlined in the aforementioned codes should be used when installing a round duct to supply combustion air from the outside.

Warranty

Our warranty does not cover damages resulting from the following:

- Operation with contaminated fill and supplementary feed water.
- Operation with contaminated combustion air.
- Exposing the boiler to pressures and temperatures higher than its certified rating.

See warranty sheet for details.

System layout

The boiler water temperature limit is factory set to 167° F (75° C).

The boiler water temperature limit can be increased by altering the adjustable high limit to increase the supply water temperature.

To minimize piping losses of the system, however, Viessmann recommends that the radiation and domestic hot water production in the system be designed for a 158° F (70° C) boiler supply water temperature.

Water quality

Treatment for boiler feed water should be considered in areas with known problems, such as where a high mineral content and hardness exist. In areas where freezing might occur, an antifreeze may be added to the system water to protect the system.

Please adhere to the specifications given by the antifreeze manufacturer. Do not use automotive silicate-based antifreeze. Please observe that an antifreeze/water mixture may require a backflow preventer within the automatic water feed and influence components such as diaphragm expansion tanks, radiation, etc. A 40% antifreeze content will provide freeze-up protection to -10° F (-23° C). Do not exceed 50% antifreeze mix ratio and do not use antifreeze other than specifically made for hot water heating systems. System also may contain components which might be antifreeze manufacturer.

Oxygen diffusion barrier under floor tubing

The boiler warranty does not cover pressure vessel failure resulting from corrosion caused by the use of underfloor plastic tubing without an oxygen diffusion barrier. Such systems without oxygen diffusion barrier must have the tubing separated from the boiler with a heat exchanger. Viessmann always recommends the use of underfloor plastic tubing with an oxygen diffusion barrier.

System Design Considerations *(continued)*

Boiler/Burner start-up

Vitocrossal 300, CT3 boilers with Weishaupt or Riello burners may require start-up by Viessmann. Please inquire with your local Viessmann sales representative to obtain details regarding the necessary prerequisites of boiler/burner start-up procedures.

IMPORTANT

To minimize delivery lead times, please ensure that critical technical information is provided at time of order. Viessmann will not process an order without site-specific information regarding available voltage and gas pressure. In addition Viessmann recommends that gas pressure information be provided in writing by the local gas utility.

Sound attenuation

Please consult a professional engineer who is specialized in noise attenuation for advice.

The burner/boiler systems, circulation pumps and other auxiliary equipment used in heating systems generate noise. This noise is transferred from the boiler room via floorboards, ceiling and walls to neighboring rooms and via the flue gas system as well as the ventilation air and exhaust air apertures into other rooms and into the open, where they may cause a nuisance.

To avoid this from happening, additional protective measures may be required which should be considered at the design stage. Subsequent measures to reduce noise nuisance frequently require extensive effort and expenditure.

Airborne noise attenuation

Frequently, modern boilers are equipped with silencer hoods or sound insulated ventilation air inlet housings. Additional silencer hoods may be used where more stringent anti-noise measures are required. These measures may be implemented later with minimal effort.

Silencer hoods are offered (usually by the burner manufacturer) for various levels of noise attenuation and are generally designed and built in accordance with specific system conditions (boiler type, fuel supply, building characteristics).

For larger systems, it may be necessary to route the ventilation air through a sound-insulated channel, in order to avoid noise nuisance outside the building.

Flue gas silencers are generally only required where higher noise protection measures are called for. Whether or not a flue gas silencer is required can be difficult to predict, because of the complexity of the creation and propagation of flame noise, the interaction between the burner, boiler and the flue gas system as well as the operating mode (flue gas system operating with positive or negative pressure).

It is advisable, therefore, to assess the noise emission into the neighborhood and to consider the sound pressure level measured at the flue gas system outlet. It should be considered at the planning stage whether silencers might become necessary later.

In planning for its possible use, it is important that sufficient space for the flue gas silencer is available behind the boiler.

Good engineering practice mandates that the exhaust pressure drop of the silencer be included in the vent size calculation.

Anti-vibration measures

Anti-vibration supports can be field supplied as an economical and effective solution to combat noise generated.

When sizing such supports, take the entire operating weight of the boiler system and, when using longitudinal anti-vibration brackets, the condition of the supporting surface into consideration.

Effective anti-vibration measures are particularly important when installing boilers into an attic. Compensators may be used to physically separate the combustion equipment from the building.

These should be installed into the boiler flow, return and safety pipe and as near as possible to the boiler.

Also insulate any braces or hanging arrangements, if installed, against sound/ vibration transmission to the building.

Seismic restrainer

Viessmann offers an engineered seismic restraining kit for compliance with local seismic requirements for buildings and structures. Please contact your local Viessmann Sales Representative for more details.

Burner Alternatives

Weishaupt Burners *1 - Linkage-less version

Boiler model	CT3-	17	22	28	37	46	57	72	89
Fully modulating burner	Model	WG20	WG30	WG30	WG40	WG40	WM-G 10/3	WM-G 10/3	WM-G 10/4

Riello Burners *1

Boiler model	CT3-	17	22	28	37	46	57	72	89
Fully modulating burner *2	Model	G750*3	G900	RS28/M	RS38/M	RS50/M	RS50/M	RS70/M	RS100/M

*1 Only the Weishaupt (low-NOx and standard head) and Riello (standard head) burner models stated are CSA certified with the Vitocrossal boiler series as indicated on the boiler rating plate.

*2 Burners are available in 2-stage and fully modulating versions.

*3 Single stage burner only.

► Contact your local Viessmann sales representative for details.

Printed on environmentally friendly (recycled and recyclable) paper.



Technical information subject to change without notice.